



# SIEBO

The outstanding full  
mobile drum screen

# Features

## Latest technology

- 55 kW engine (EU Stage V, EPA Tier 4 final) without SCR/AdBlue
- user friendly display with all functions at a glance



## Galvanized conveyor belt frames

- all conveyor belt frames are hot-dip galvanized for a long life time also in difficult conditions.



## Coarse grain conveyor belt

- the 1000 mm wide coarse grain conveyor belt is 5500 mm long. Longer versions optionally available.
- tilting stepless changeable
- speed stepless changeable



## Fines grain conveyor belt

- 1000 mm wide fines conveyor belt is 7200 mm long. Longer versions optionally available.
- optionally available as a one-piece or two-piece conveyor.

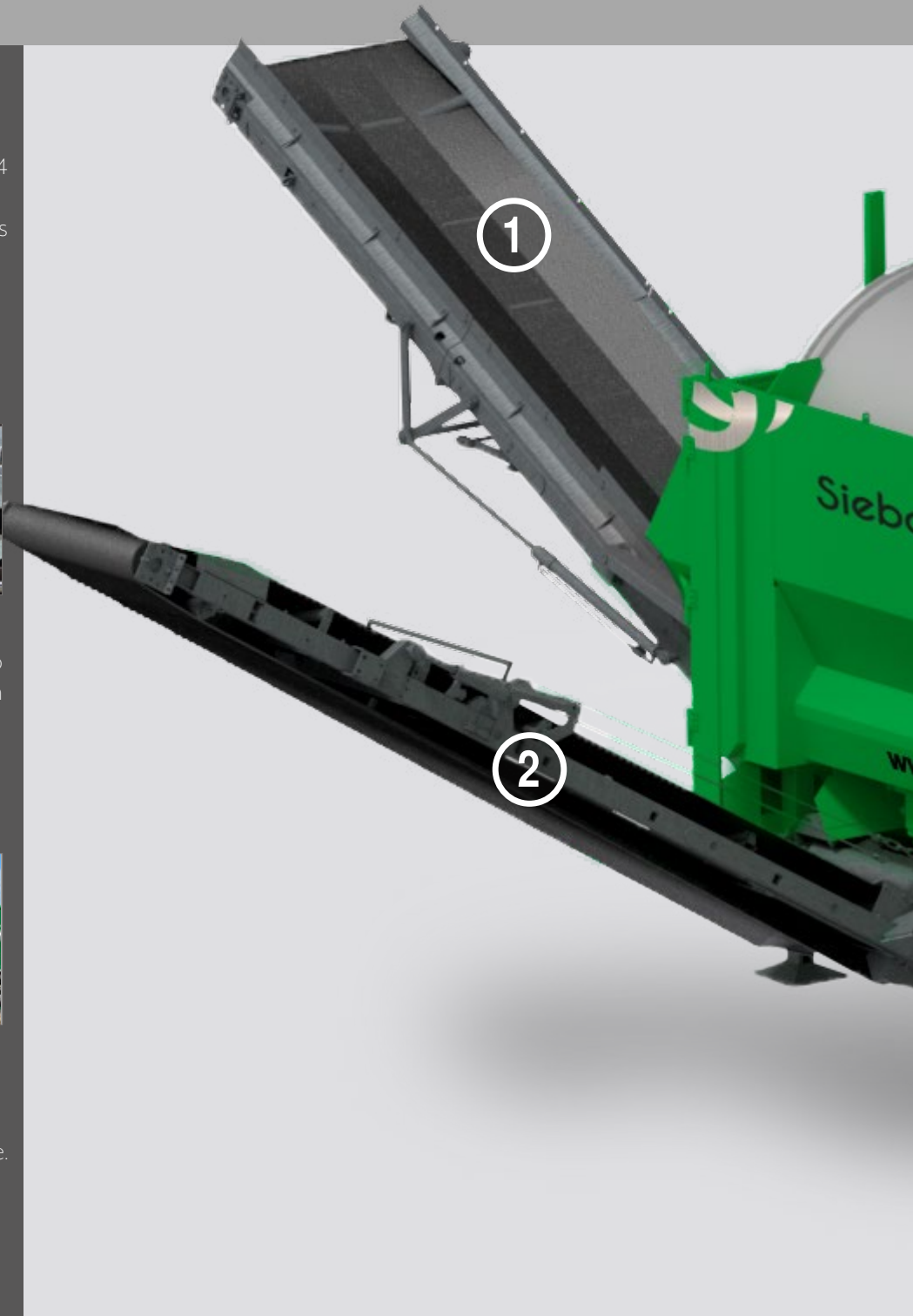

## Hopper

- huge hopper with a width of 4000 mm and a volume of 6 m<sup>3</sup>.
- optionally available with pluggable side wall extensions

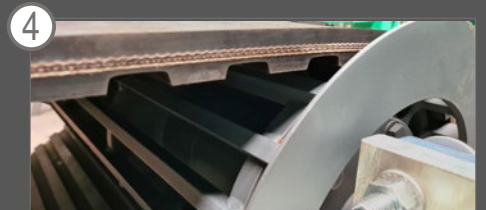

## Positive drive hopper belt

- nearly maintenance free
- no slipping even with heavy material and full hopper

## customize your machine!

- Cleanfix® reversing fan
- pluggable hopper extensions
- remote control
- longer conveyor belts
- magnet head pulley for fines- and coarse grain conveyor belt

Not the right one?

Please contact us!

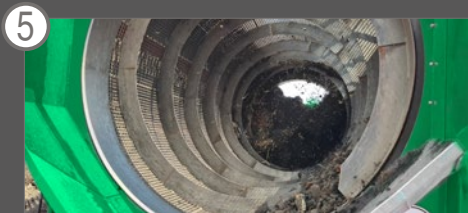

### Screening drum

- 2000 mm diameter and 4550 mm length for best screening results
- optionally available as a punch plate steel drum or a segment drum
- trommel is supported by eight big dimensional carrier wheels



### Maintenance friendly door

- the sidewall is one big door
- easy access for a quick and easy drum change

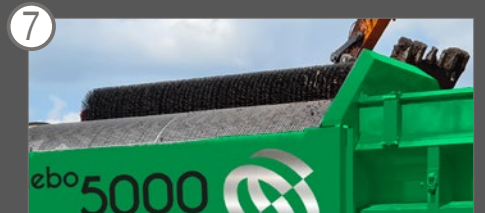

### Cleaning brush

- powerful, hydraulic foldable cleaning brush with 700 mm diameter
- automatic self cleaning system
- no plugging screening holes

# Technical data Siebo 5000

## Under carriage 2-axle trailer

Admissible total weight 16000 kg

## Dimensions

Machine length 14900 mm  
Machine width 6800 mm  
Machine height 4000 mm

Transport length 11000 mm  
Transport width 2550 mm  
Transport height 4000 mm

## Hopper

Volume 6 m<sup>3</sup>  
Feeding height 2820 mm  
Feeding width 4000 mm

## Screening drum

Drum length 4550 mm  
Drum diameter 2000 mm

## Conveyor belts

Fines conveyor length (one-piece) 7200 mm  
Fines conveyor width 1000 mm  
Discharge height (30°) 3500 mm

Overs conveyor length 5500 mm  
Overs conveyor width 1000 mm  
Discharge height (30°) 3500 mm

## Drive

Power 55 kW /  
75 PS (at 2200 rpm)  
Emission class EU Stage 5 EPA  
Tier 4 final

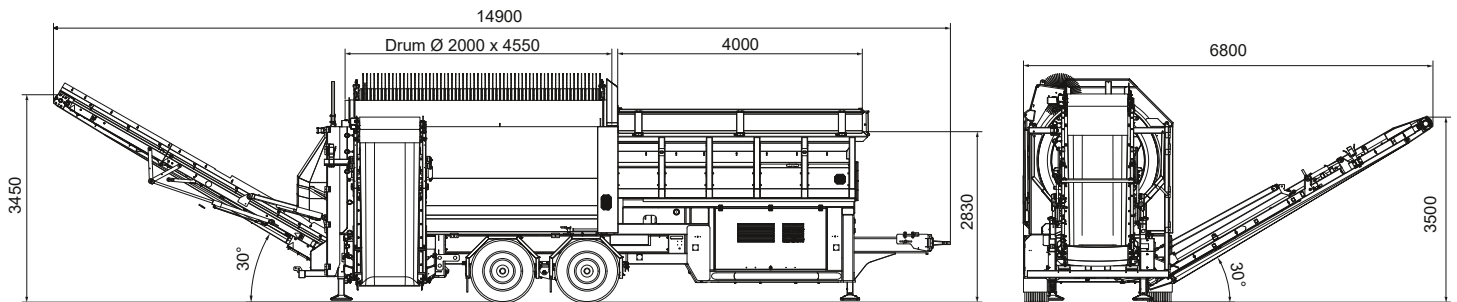

**HAAS**<sup>®</sup>  
Recycling-Systems

HAAS Holzzerkleinerungs-  
und Fördertechnik GmbH  
Unter den Weiden 6  
56472 Dreisbach / GERMANY

Tel.: +49 2661 9865-0  
Fax: +49 2661 9865-20

info@haas-recycling.de